



# Ceilometer CL31

for cloud height detection



Vaisala Ceilometer CL31 is a compact and lightweight instrument for cloud base height and vertical visibility measurements. It detects 3 cloud layers simultaneously. CL31 uses a pulsed diode laser LIDAR (light detection and ranging) technology. CL31 is ideal for aviation and meteorological applications.

### Measurement starts from ground level

The enhanced single-lens technology applied in CL31 ensures excellent performance starting at a height of virtually zero. This is due to the strong and stable signal over the whole measurement range. The single-lens technology provides unsurpassed reliability during precipitation, low clouds and ground based obscurations, which are the most critical phenomena in aviation safety.

### Fast measurement

Fast measurement helps to detect thin cloud patches below a solid cloud base. CL31 provides a full backscatter profile for data visualization and research purpose.

The CL31 beam can be directed either vertically or tilted. The tilting option together with the novel optics design provides enhanced performance during precipitation by improving the protection given by the shield. In the measurement unit, a tilt angle sensor automatically corrects the measured cloud distance reading to vertical cloud base height.

### Extensive self-diagnostics

CL31 is fully automatic. In addition to cloud height data, the messages contain instrument status information based on comprehensive self-diagnostic routines.

In case of malfunction, the diagnostics help users to identify the failed module. CL31 features practical modularity and its easy-access door ensures fast servicing and high data availability.

### Easy installation and maintenance

CL31 is easy to install. It has a radiation shield that protects the unit during precipitation and against excessive heat or cooling in extreme temperatures. The automatic window blower with heater improves performance by keeping the window clean and dry. In cold conditions heating prevents frost generation on the window.

#### Features

- Measurement range from 0 to 7.6 km (from 0 to 25 000 feet)
- Modular design for easy installation and maintenance
- Second-generation, advanced single-lens optics provides excellent performance also at low altitudes
- Fast measurement enables detection of thin cloud layers below a solid cloud base
- Reliable operation in all weather; unsurpassed performance in vertical visibility and cloud detection during precipitation
- Latest technology from the world-leading manufacturer - based on the experience from more than 5000 installed Vaisala ceilometers worldwide
- Extensive self-diagnostics with fault analysis

#### Data messages

- Cloud hits (up to 3 layers) and status information
- Cloud hits, status, and backscatter profile
- Emulation of CT12K, CT25K, LD-25/40
- Sky condition (optional)

# Technical data

## Operating environment

Operating temperature	-55 ... +60 °C (-67 ... +140 °F),
Operating humidity	0 ... 100 %RH
Wind tolerance	Up to 55 m/s (123 mph)
Vibration	Lloyds Register / IEC 60068-2-6 5 ... 13.2 Hz, ±1.0 mm 13.2 ... 100 Hz, ±0.79 g 9.1 ... 150 Hz, ±0.5 g
Pollution degree	2
Maximum operating altitude	3000 m (approx. 9800 ft)
IP rating	IP65 (measurement unit) IPX6 (with radiation shield)

## Inputs and outputs

Operating voltage	115/230 V AC 100 – 127 V AC, 207 – 253 V AC
-------------------	--

Power consumption	
Power consumption (typical)	310 W
Measurement unit	15 W
Internal heater	100 W
Window conditioner heater	175 W
Window blower	20 W
Frequency (min/max)	50/60 Hz
No-break power supply	12 V sealed lead-acid battery, 2 Ah
Backup battery	12 V internal, 2 Ah
Overvoltage protection	Low-pass filter, VDR
Overvoltage category	II

Interfaces	
Data	<ul style="list-style-type: none"> <li>RS-232</li> <li>RS-485, multidrop, 2-wire</li> <li>DXL421 modem module</li> <li>LAN (Ethernet) interface option</li> </ul>
Maintenance	RS-232

Baud rate	
RS-232 / RS-485	300 ... 57 600 bps
Modem V.21, V.22	300 ... 1200 bps

## Mechanical specifications

Tilt positions	Vertical or 12° tilted
----------------	------------------------

Dimensions	
Measurement unit	620 × 235 × 200 mm (24.41 × 9.25 × 7.87 in)
Height with radiation shield	1190 mm (47 in)
Total	1190 × 335 × 324 mm (46.85 × 13.19 × 12.76 in)

Weight	
Measurement unit	12 kg (26.5 lb)
Radiation shield and blower	19 kg (41.8 lb)
Total	31 kg (68 lb)

Plywood transport container	
Container size	1400 × 490 × 450 mm (55 × 19.30 × 17.72 in)
Container weight	47 kg (103.6 lb)

## Measurement performance

Measurement range	0 ... 7.6 km (0 ... 25 000 ft)
Measurement resolution	10 m (33 ft) or 5 m (16 ft), selectable
Reporting interval	Programmable 2 ... 120 s, or polling
Measurement interval	2 s default
Distance measurement accuracy against a hard target	Greater of ±1 % or ±5 m (16 ft)

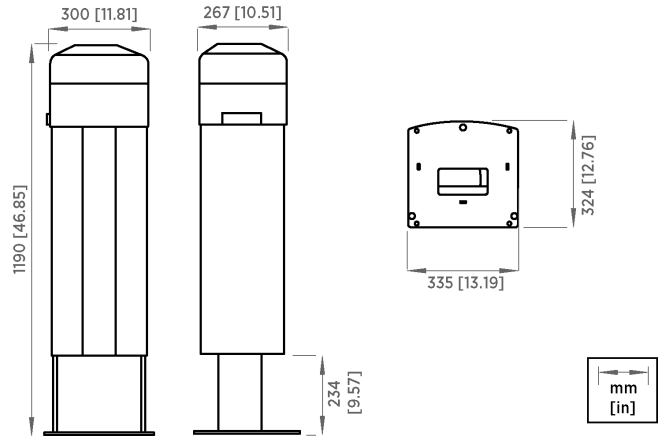

## Spare parts and accessories

Cable termination box with extra transient protection	Termbox-1200
PC maintenance cable	QMZ101
Shock absorbing mounting pad for ship installations	CT35022
Modem	DXL421
Attachment mechanics for radio modem antenna	CLRADIOKIT
Graphical User Interface for Ceilometers	CL-VIEW
Boundary Layer View Software for Ceilometers	BL-VIEW
Bird deterrent	CL31BIRDKIT
Air Quality Plug and Play Package for Ceilometer with laptop and pre-installed BL-View	CLAQPACKAGE

## Compliance

EU directives and regulations	LVD, EMC, RoHS
EMC immunity	IEC/EN 61326-1, industrial environment
EMC emissions	CISPR 32 / EN 55032, Class B EN 61000-3-2 EN 61000-3-3
Electrical safety	IEC/EN 60950
Environmental	IEC/EN 63000
Eye safety	IEC/EN 60825-1:2014
Compliance marks	CE, RCM, China RoHS, UKCA

