



## 3M™ Simtronics™ GD1-H<sub>2</sub>S Laser Open Path Gas Detector



### Presentation

The GD1 has been designed with features that provide an effective response to the detection of gas hazards in a wide range of industrial environments from offshore production facilities to wastewater treatment plants.

At the heart of the detector is a tunable laser diode that eliminates environmental effects from sun, rain, sand, and fog. The laser scans single absorption lines where there is no interference from other gases.

Unlike traditional methods for detecting H<sub>2</sub>S (MOS or EC cell), the GD1 needs no recalibration and can replace multiple standard detectors to cover the same risk.

The complete optomechanical design and construction is so stable that an ultra fast response time can be achieved whilst providing unparalleled service life and detector stability, thus saving on maintenance and service costs.

The detector is supplied with worldwide hazardous area approvals, is suitable for SIL2 applications and comes with a 5 year warranty.

### Features

- Fail safe
- Fast response time
- Calibration free
- Operates up to 98% of obscuration

# 3M™ Simtronics™ GD1-H<sub>2</sub>S

## Laser Open Path Gas Detector

### Technical data

#### General

Detection method IR-	New IR laser scanning
Source	Tunable laser diode Laser Class 1, eye safe
Detected gas	H <sub>2</sub> S
Range	0-200 ppm*m 0-500 ppm*m 0-1000 ppm*m 0-2000 ppm*m 0-5000 ppm*m 0-20000 ppm*m
Path length	5 - 75 m
Self test	Continuous
Calibration	Factory set, no field recalibration

#### Performance

Accuracy	<±4% of full range
Repeatability	<±4% of full range
Response time	<5 sec

#### Optics

Alignment	±0.30 Degree
Optics	Heated (transmitter and receiver)
Tolerable obscuration	98% (Allowable signal loss)

#### Output signal

Standard	4-20mA source or sink HART®
Fault signals	Fault 1 mA Beam block 2 mA Warning 3 mA (optional)

#### Electrical

Power supply	24V DC, range (18 - 32V DC)
Power consumption	<15 W
Cable entry	M25

#### Temperature range

Storage	-55°C to +65°C (-67°F to +149°F)
Operating	-55°C TO + 65°C (-67°F TO +149°F)
Atex flameproof	-55°C to + 75°C (-67°F to +167°F)
Humidity (operation)	100% RH

#### Material

Tx and rx housing	Stainless steel (ASTM 316)
Junction box	Grp

#### Weight

Approx.	5.5 Kg (12 lbs) per tx or rx
Approx.	2.0 Kg (4.4 Lbs) per tx or rx junction box

#### Dimensions

Tx and rx housing	Ref. Outline drawing
-------------------	----------------------

#### Warranty

5 Years full warranty on detector system

#### Approvals

Atex rating tx/rx	II 2 g	Ex d [op is] IIC T6/T5 Gb
Atex rating jrb	II 2 g	Ex e IIC T5 Gb
Iecex	DNV 10.0002X (JB: PRE 14.0040)	
Ingress	IP66/IP67 according to IEC 60529	
Sil	Suitable for use in SIL2 systems	

#### Accessories

GD1-X00-TT01	Alignment kit
GD1-X00-TT02	Test cell

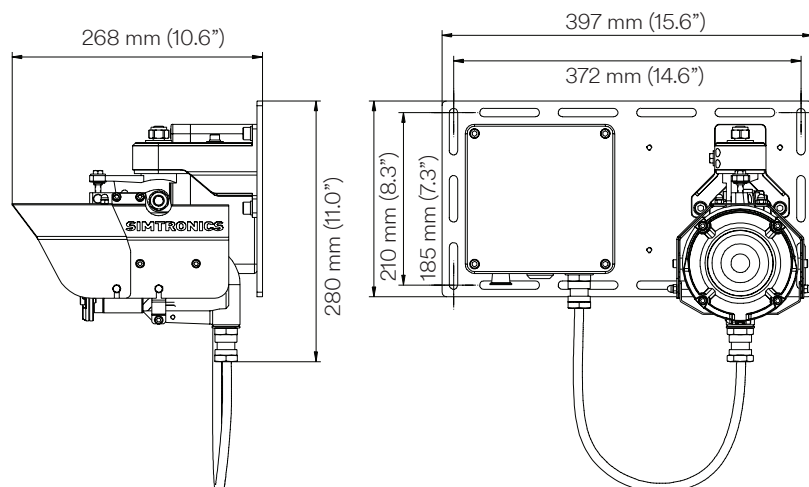

3M Gas & Flame Detection quality assurance programmes demand the continuous assessment and improvement of all our products. Information in this leaflet could thus change without notification and does not constitute a product specification.



GF-00257D-EN  
Copyright © 2018 3M, 3M Gas & Flame Detection.  
All rights reserved. [gasdetection.3m.com](http://gasdetection.3m.com)  
[gasandflamedetection@mmm.com](mailto:gasandflamedetection@mmm.com)

**AMERICAS - Texas (USA)**  
4055 Technology Forest Blvd.  
The Woodlands, TX 77381  
Tel.: +1-800-247-7257  
Fax: +1-281-292-2860

**EMEA**  
Z1 Est, Rue Orfila,  
CS 20417  
62027 ARRAS CEDEX, France  
Tel.: +33-3-21-60-80-80  
Fax: +33-3-21-60-80-00

**ASIA PACIFIC**  
290 Guiqiao Road  
Pudong, Shanghai 201206  
People's Republic of China  
Tel.: +86-21-3127-6373  
Fax: +86-21-3127-6365